

Appdu Rozak
0813-2828-2659
www.isuzusunter.com

ISUZU
ELF
NGR B

**IRIT MAKSIMAL,
MUAT PENUMPANG
OPTIMAL**



TKDN
CERTIFIED

*Gambar pada brosur ini hanya ilustrasi, mungkin ada perbedaan dengan aktual kendaraan
**Mesin common rail pada Isuzu Giga sejak tahun 2011

REAL PARTNER. REAL JOURNEY.

SPEKIFIKASI TEKNIS

SPEKIFIKASI		NOR B
DIMENSI / DIMENSION		
Panjang / Overall Length [OAL]	mm	7,425
Lebar / Overall Width [OWI]	mm	2,100
Tinggi / Overall Height [OHI]	mm	2,060
Jarak Sumbu / Wheelbase [WBI]	mm	4,175
Julur Depan / Front Overhang [FOH]	mm	1,110
Julur Belakang / Rear Overhang [ROH]	mm	2,140
Jarak Terendah Tanah / Minimum clearance [HtH]	mm	200
Jajak Depan / Front Tread [AWI]	mm	1,680
Jajak Belakang / Rear Tread [CWI]	mm	1,650
MESIN / ENGINE		
Model	4HL1-1TCS	
Tipe / Type	Direct Injection, Commonrail, SOHC, 4 Cylinder, VGS Turbo Intercooler	
Sistem Kontrol Emisi	EURO4 with EGR & DDC	
Diameter x Langkah / Bore x Stroke	mm	115 X 115
Isi Silinder / Piston Displacement	cc	4,778
Tenaga Maksimum / Maximum Power	PS/rpm	150 / 2,600
Torsi Maksimum / Maximum Torque	Kgm/rpm	41 / 1,400 - 2,600
TRANSMISI / TRANSMISSION		
Model	MYV65	
Perbandingan Gigi / Gear Ratio	1st	5.979
	2nd	3.434
	3rd	1.862
	4th	1.297
	5th	1.000
	6th	0.759
Perbandingan Gigi Terakhir / Final Gear Ratio		5.701
		5.125

DIMENSI

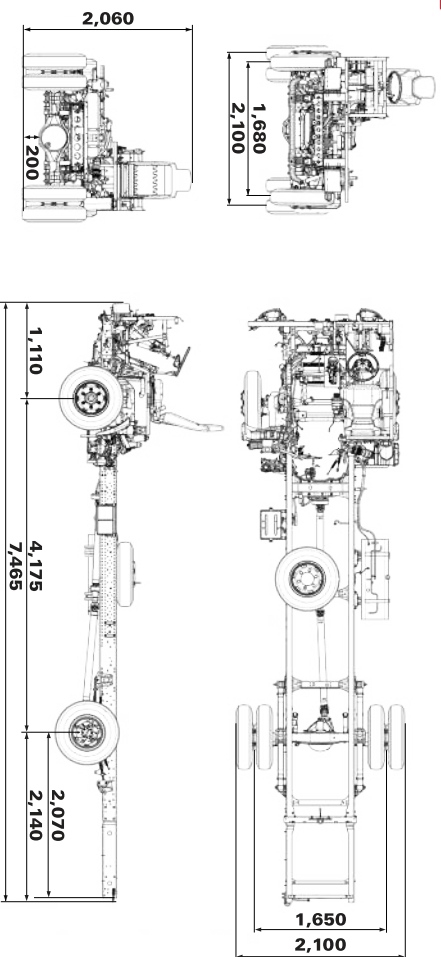

SPEKIFIKASI

SPEKIFIKASI		NOR B
BERAT / WEIGHT		
Berat Kosong Kendaraan / Curb Weight	kg	2,312
Berat Total Kendaraan / Gross Vehicle Weight [GVM]	kg	8,000
Kapasitas Gardan Depan / Capacity Front Axle	kg	3,000
Kapasitas Gardan Belakang / Capacity Rear Axle	kg	5,000
REMI / BRAKE		
Tipe/Type	Hydraulic	
Rem Kaki / Service Brake	Hydraulic Brake Booster	
Rem Tangan / Hand Brake	Expanding pada transmisi belakang	
Sistem Pengemaman Gas Buang / Exhaust Brake	Exhaust brake, tuas berada di stir	
RODA / TYRE		
Ukuran Ban	7.50-16-14PR	
Ukuran Velg	16 X 6.00	
SUSPENSI / SUSPENSION		
Depan / Front	Semi elliptical laminated leaf spring	
Belakang / Rear	dengan shock absorber berdaya ganda	
LAIN-LAIN / OTHERS		
Kapasitas Tangki / Fuel Tank Capacity	ltr	100
Radius Pilar Minimum / Minimum Turning Radius m		7.5
Daya Tarik Maksimum / Maximum Gradeability %		39
Kecepatan Maksimum / Maximum Speed km/h		107
Aki / Accu	V-Ah	2 X 12V-65 Ah
Alternator	V-A	24-80
Kamera Mundur / Reverse Parking Camera		Ada
Audio Head Unit		Ada
Garansi / Warranty		3 Tahun / 100,000 km

*Untuk meningkatkan mutu dan penyediaan dengan perkembangan teknologi, spesifikasi dapat berubah sewaktu-waktu tanpa pemberitahuan.

**Muster merupakan contoh sebagai referensi di lapangan.

APLIKASI

MEDIUM BUS

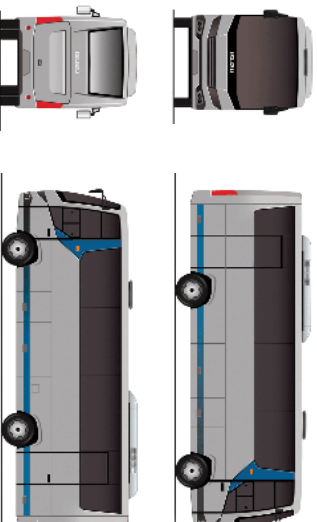

SCAN INI
UNTUK
INFORMASI
LEBIH LANJUT

